

CrimpRite™/MD

Crimprite Self Positioning Pex Crimp rings for insert fittings insure a Proper Crimp everytime !

“PATENT PENDING”

1/2”

3/4”



GET POSITIVE & PROFESSIONAL RESULTS !

- The unique Patent Pending design aligns the crimp ring over the 2 sealing barbs of pex crimp insert fittings.
- Crimprite rings prevent expensive and frustrating call backs due to leaking misaligned crimps.
- The Crimprite eliminates the sliding and moving of rings during installation.
- To install Crimprite rings use standard Pex Crimp Tools.
- Crimprite complies with CSA Standard B137.5
- Use Crimprite on Brass or Polyalloy fittings, Pex Ready Valves & Manifolds.

Available in the following sizes and packaging:

PART	DESCRIPTION	INNER PACK	MASTER PACK	UPC
1411011	CRIMPRITE 1/2" PEX CRIMP RING BULK	100	2000	061788110114
1411022	CRIMPRITE 3/4" PEX CRIMP RING BULK	100	1200	061788110220
1477011	CRIMPRITE 1/2" PEX CRIMP RING (BG)	20	240	061788770110
1477022	CRIMPRITE 3/4" PEX CRIMP RING (BG)	20	200	061788770226

HOW TO MAKE CRIMP CONNECTIONS

Please read the instructions thoroughly before beginning.

- **STEP 1** Squarely cut tubing with the pipe cutter. Burrs, jagged or irregular cuts may result in an improper connection.
- **STEP 2** Slide the correct sized copper crimp ring over the PEX tubing.
- **STEP 3** Insert the fitting into the tubing up to the fitting shoulder.
- **STEP 4** Using a calibrated crimp tool for the correct size, centre the crimping tool jaws over the ring. **HOLD THE TOOL AT 90°** to the the fitting and close the jaws completely. Crimp only one time. If crimped more than once, you must cut out the connection and begin at Step 1.

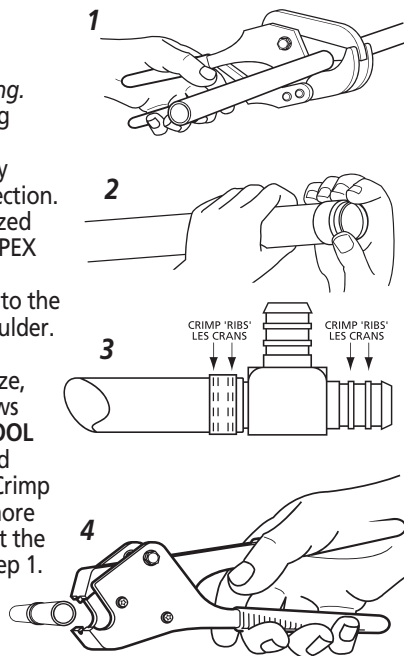

CHECK EVERY CRIMP! Each crimp connection should be checked with a 'Go / No Go' gauge to ensure proper installation. When checking the crimp with the 'Go / No Go' gauge, make sure to push straight down on the crimp ring. A proper crimp has been established if the 'Go' side of the gauge fits over and can rotate around the circumference of the crimp ring.

'GO' / 'NO GO' GAUGE Normal wear and tear can effect gauge accuracy so periodically check gauge with a measuring device or change to a new gauge regularly to ensure accuracy. An improper crimp is when (1) the 'Go' side does not fit over the ring -OR- (2) the 'No Go' side does fit over the crimp ring.

